

2

1

∅ = Diameter

∅ = Diameter

Available ∅ sizes include:

- 1/32
- 1/16
- 3/32
- 1/8
- 3/16
- 1/4
- 5/16
- 3/8

ETC.

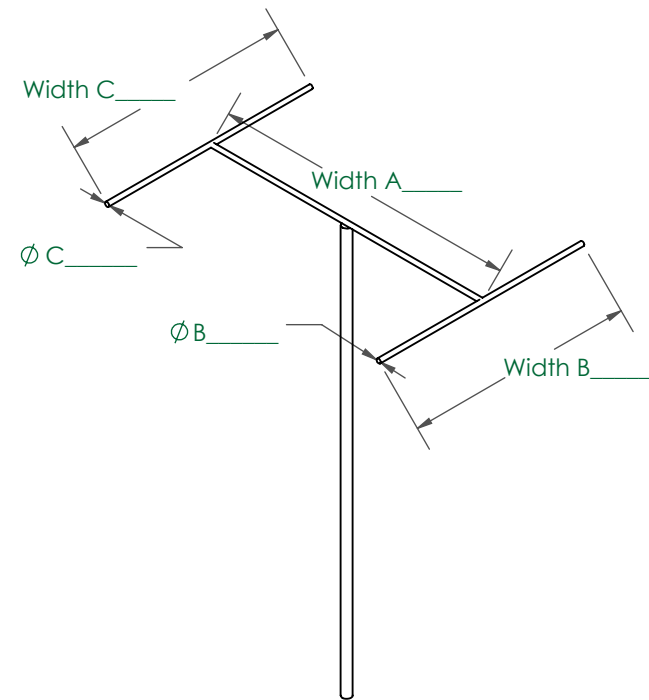
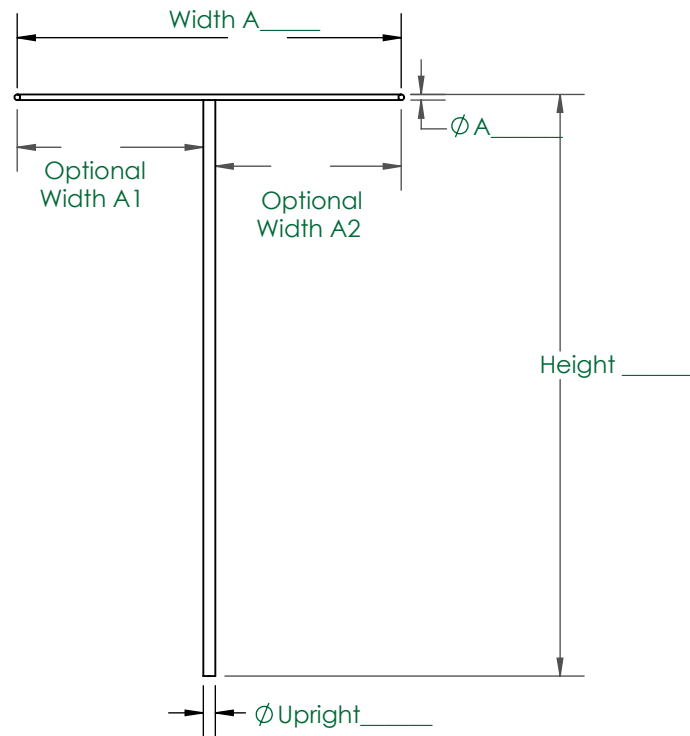

B

B

A

A

	NAME	DATE
DRAWN	EWS	4/8/20
CHECKED	XXXX	XXXX
ENG APPR.	XXXX	XXXX
MFG APPR.	XXXX	XXXX

10-31 INC		
TITLE:		
Custom Size H-Arm		
SIZE	DWG. NO.	REV
A	H-ARM	A
SCALE: 1:4	WEIGHT: 0.230	SHEET 1 OF 1

PROPRIETARY AND CONFIDENTIAL	UNLESS OTHERWISE SPECIFIED:	MATERIAL
	DIMENSIONS ARE IN INCHES	Steel
	TOLERANCES:	FINISH
	FRACTIONAL: ±1/16	Painted Black
ANGULAR: MACH ± 0.01 BEND ± 1.0	ONE PLACE DECIMAL ± 0.06	ALL EXT. MACH. SURFACES ³² OR BETTER DEBURR AND BREAK ALL SHARP EDGES
TWO PLACE DECIMAL ± 0.03		
THREE PLACE DECIMAL ± 0.03		

COMMENTS:
XXXX
DO NOT SCALE DRAWING

2

1