

2

1

∅ = Diameter

∅ = Diameter

Available ∅ sizes include:

- 1/32
- 1/16
- 3/32
- 1/8
- 3/16
- 1/4
- 5/16
- 3/8

ETC.

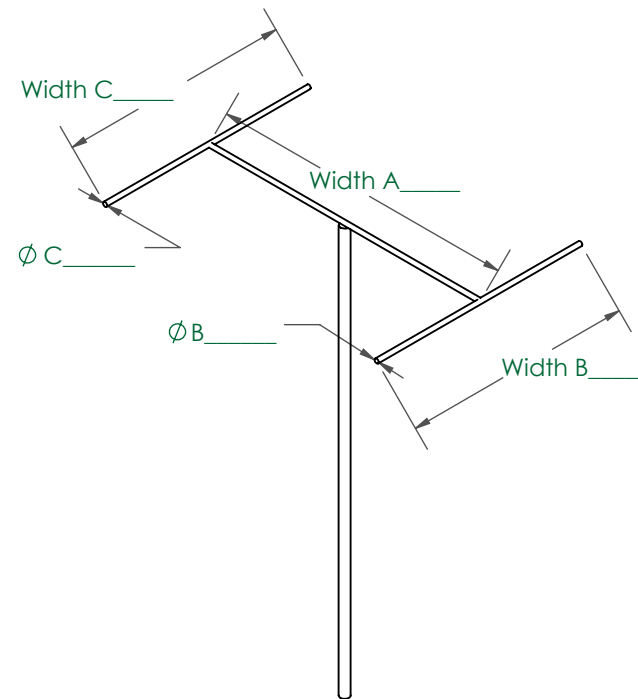
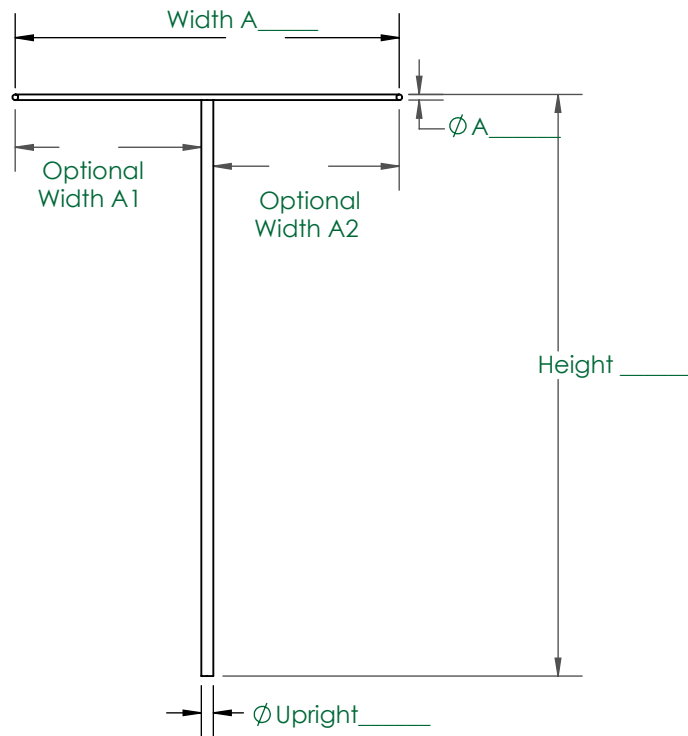

B

B

A

A

	NAME	DATE
DRAWN	EWS	4/8/20
CHECKED	XXXX	XXXX
ENG APPR.	XXXX	XXXX
MFG APPR.	XXXX	XXXX

10-31 INC
 TITLE:
 Custom Size H-Arm

COMMENTS: XXXX
DO NOT SCALE DRAWING

SIZE A	DWG. NO. H-ARM	REV A
SCALE: 1:4	WEIGHT: 0.230	SHEET 1 OF 1

PROPRIETARY AND CONFIDENTIAL THE INFORMATION CONTAINED IN THIS DRAWING IS THE SOLE PROPERTY OF 10-31 INCORPORATED. ANY REPRODUCTION IN PART OR AS A WHOLE WITHOUT THE WRITTEN PERMISSION OF 10-31 INCORPORATED IS PROHIBITED.	UNLESS OTHERWISE SPECIFIED:	MATERIAL Steel
	DIMENSIONS ARE IN INCHES	FINISH Painted Black
	TOLERANCES: FRACTIONAL ± 1/16 ANGULAR: MACH ± 0.01 BEND ± 1.0	ALL EXT. MACH. SURFACES ³² ✓ OR BETTER DEBURR AND BREAK ALL SHARP EDGES
	ONE PLACE DECIMAL ± 0.06 TWO PLACE DECIMAL ± 0.03 THREE PLACE DECIMAL ± 0.03	

2

1

2

1

∅ = Diameter

Please try to enter all dimensions as INCHES.
If you need to use CM please indicate it clearly.

Please enter a material and finish at the bottom
or call to discuss your options.
1(800) 862 - 9869

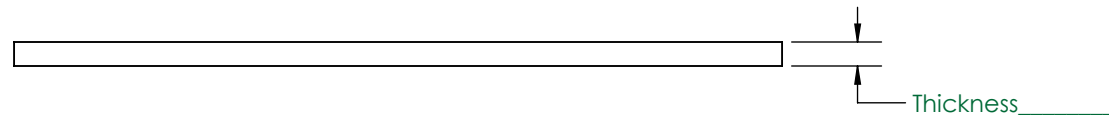
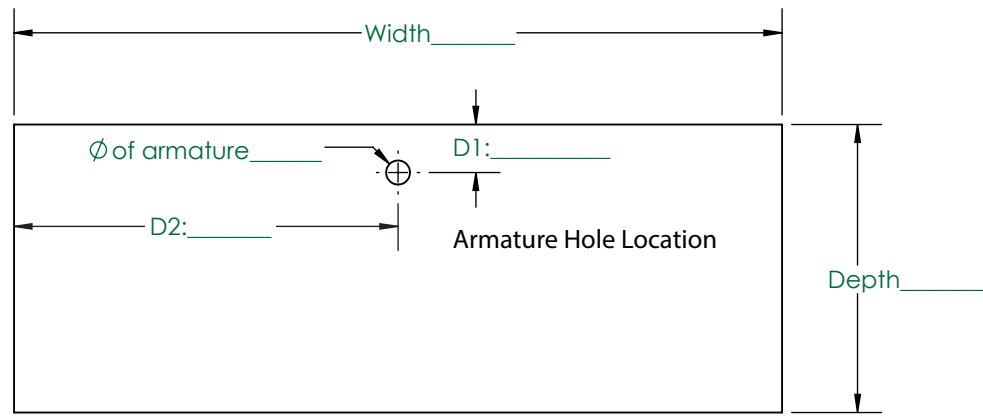
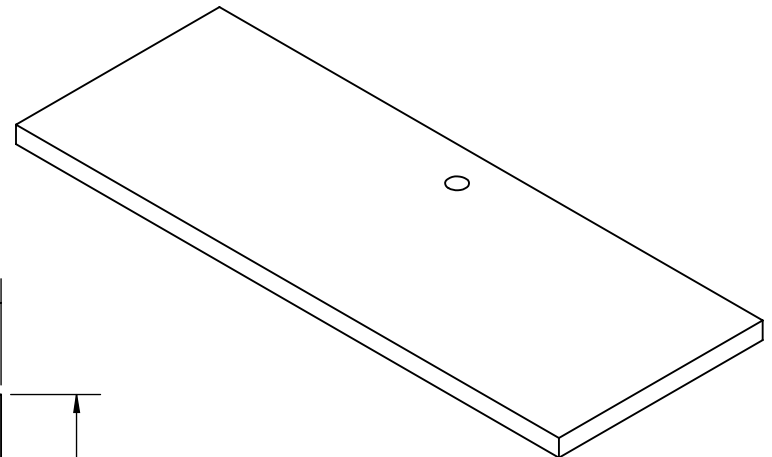

Typical thickness's include: 1/4, 3/8, & 1/2 Inch

Common Materials:

- Steel
- Brass
- Acrylic
- Wood

Common Finishes:

- Painted (Black, White, Clear, Primed, Etc)
- Patinated
- Stained
- Custom options available

	NAME	DATE
DRAWN	XXXX	XXXX
CHECKED	XXXX	XXXX
ENG APPR.	XXXX	XXXX
MFG APPR.	XXXX	XXXX

10-31 INC		
TITLE: Armature Base, Custom size		
SIZE A	DWG. NO. Custom Base	REV A
SCALE: 1:2	WEIGHT: 1.688	SHEET 1 OF 1

PROPRIETARY AND CONFIDENTIAL THE INFORMATION CONTAINED IN THIS DRAWING IS THE SOLE PROPERTY OF 10-31 INCORPORATED. ANY REPRODUCTION IN PART OR AS A WHOLE WITHOUT THE WRITTEN PERMISSION OF 10-31 INCORPORATED IS PROHIBITED.	UNLESS OTHERWISE SPECIFIED:	MATERIAL
	DIMENSIONS ARE IN INCHES	FINISH
	TOLERANCES: FRACTIONAL ± 1/16 ANGULAR: MACH ± 0.01 BEND ± 1.0	ALL EXT. MACH. SURFACES ³² OR BETTER DEBURR AND BREAK ALL SHARP EDGES
	ONE PLACE DECIMAL ± 0.06 TWO PLACE DECIMAL ± 0.03 THREE PLACE DECIMAL ± 0.015	

COMMENTS:

DO NOT SCALE DRAWING

B

B

A

A

2

1