

2

1

∅ = Diameter

∅ = Diameter

Available ∅ sizes include:

- 1/32
- 1/16
- 3/32
- 1/8
- 3/16
- 1/4
- 5/16
- 3/8

ETC.

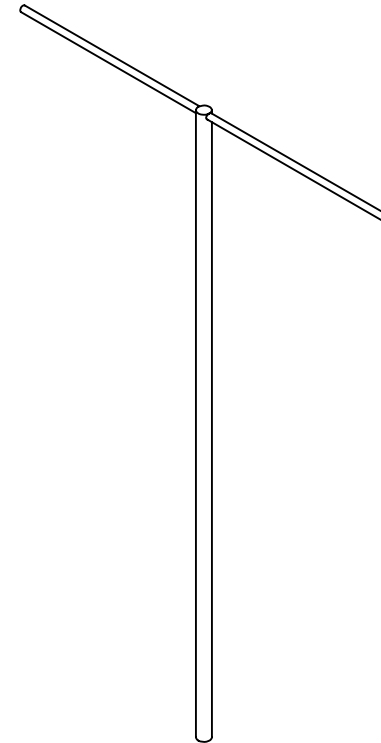
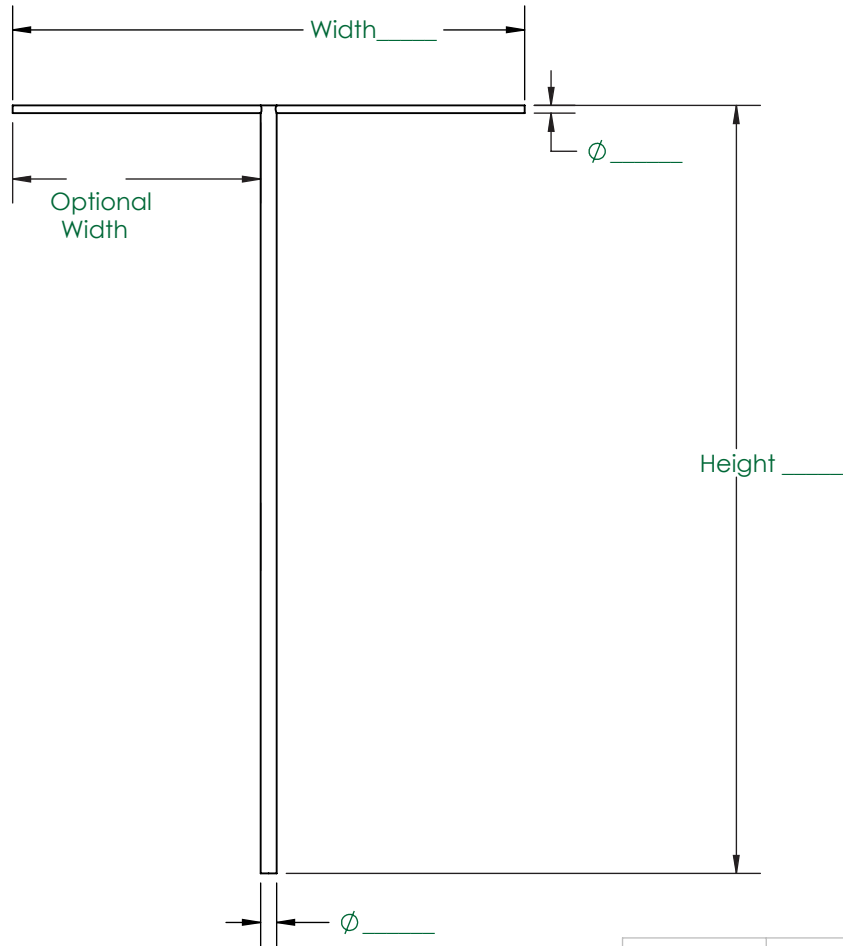

B

B

A

A

Please fill out all the dimensions to the best of your ability.  
 If you have questions or need assistance call 1 (800) 862- 9869

	NAME	DATE
DRAWN	EWS	4/8/20
CHECKED	XXXX	XXXX
ENG APPR.	XXXX	XXXX
MFG APPR.	XXXX	XXXX

10-31 INC

TITLE:  
**Custom Size T-Arm**

**PROPRIETARY AND CONFIDENTIAL**

THE INFORMATION CONTAINED IN THIS DRAWING IS THE SOLE PROPERTY OF 10-31 INCORPORATED. ANY REPRODUCTION IN PART OR AS A WHOLE WITHOUT THE WRITTEN PERMISSION OF 10-31 INCORPORATED IS PROHIBITED.

UNLESS OTHERWISE SPECIFIED:  
 DIMENSIONS ARE IN INCHES  
 TOLERANCES:  
 FRACTIONAL ± 1/16  
 ANGULAR: MACH ± 0.01 BEND ± 1.0  
 ONE PLACE DECIMAL ± 0.06  
 TWO PLACE DECIMAL ± 0.03  
 THREE PLACE DECIMAL ± 0.03

MATERIAL: **Steel**  
 FINISH: **Painted Black**  
 ALL EXT. MACH. SURFACES <sup>32</sup> OR BETTER  
 DE-BURR AND BREAK ALL SHARP EDGES

COMMENTS:  
 XXXX  
 DO NOT SCALE DRAWING

SIZE	DWG. NO.	REV
<b>A</b>	Custom T-Arm	<b>A</b>
SCALE: 1:3	WEIGHT: 0.212	SHEET 1 OF 1

2

1

2

1

∅ = Diameter

Please try to enter all dimensions as INCHES.  
If you need to use CM please indicate it clearly.

Please enter a material and finish at the bottom  
or call to discuss your options.  
1(800) 862 - 9869

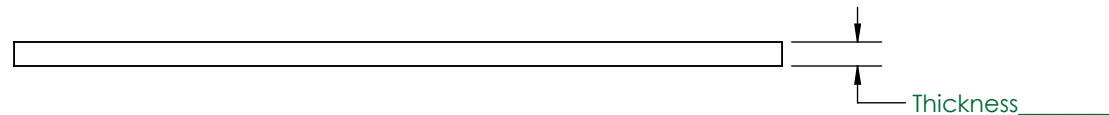
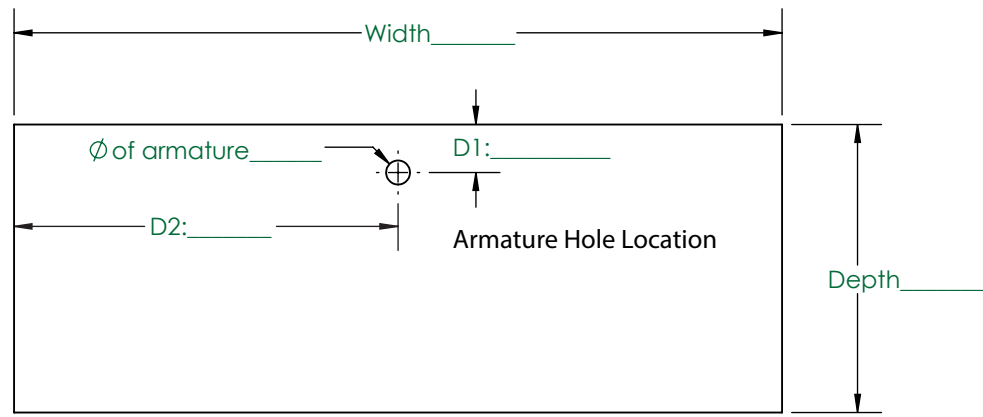
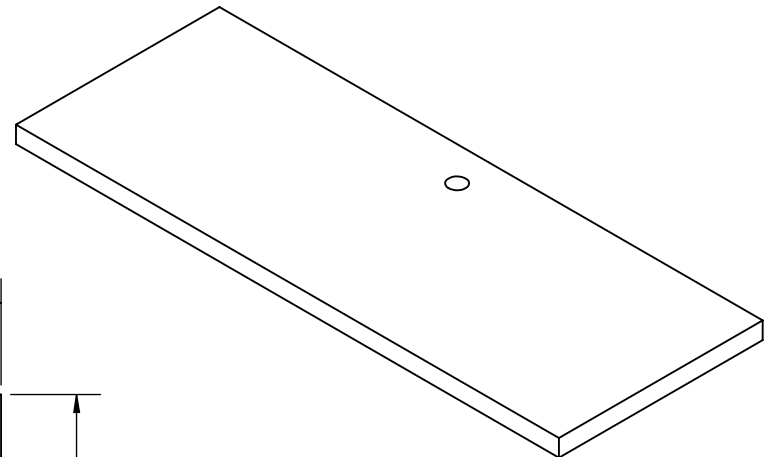

Typical thickness's include: 1/4, 3/8, & 1/2 Inch

**Common Materials:**

- Steel
- Brass
- Acrylic
- Wood

**Common Finishes:**

- Painted (Black, White, Clear, Primed, Etc)
- Patinated
- Stained
- Custom options available

	NAME	DATE
DRAWN	XXXX	XXXX
CHECKED	XXXX	XXXX
ENG APPR.	XXXX	XXXX
MFG APPR.	XXXX	XXXX

<b>10-31 INC</b>		
TITLE: <b>Armature Base, Custom size</b>		
SIZE <b>A</b>	DWG. NO. <b>Custom Base</b>	REV <b>A</b>
SCALE: 1:2	WEIGHT: 1.688	SHEET 1 OF 1

<b>PROPRIETARY AND CONFIDENTIAL</b>  THE INFORMATION CONTAINED IN THIS DRAWING IS THE SOLE PROPERTY OF 10-31 INCORPORATED. ANY REPRODUCTION IN PART OR AS A WHOLE WITHOUT THE WRITTEN PERMISSION OF 10-31 INCORPORATED IS PROHIBITED.	UNLESS OTHERWISE SPECIFIED:	MATERIAL
	DIMENSIONS ARE IN INCHES	FINISH
	TOLERANCES: FRACTIONAL ± 1/16 ANGULAR: MACH ± 0.01 BEND ± 1.0	ALL EXT. MACH. SURFACES <sup>32</sup> OR BETTER DEBURR AND BREAK ALL SHARP EDGES
	ONE PLACE DECIMAL ± 0.06 TWO PLACE DECIMAL ± 0.03 THREE PLACE DECIMAL ± 0.015	

COMMENTS:  
  
DO NOT SCALE DRAWING

B

B

A

A

2

1